



# Design No. V473 BXUV.V473 Fire-resistance Ratings - ANSI/UL 263

Page Bottom

## Design/System/Construction/Assembly Usage Disclaimer

- Authorities Having Jurisdiction should be consulted in all cases as to the particular requirements covering the installation and use of UL Certified products, equipment, system, devices, and materials.
- Authorities Having Jurisdiction should be consulted before construction.
- Fire resistance assemblies and products are developed by the design submitter and have been investigated by UL for compliance with applicable requirements. The published information cannot always address every construction nuance encountered in the field.
- When field issues arise, it is recommended the first contact for assistance be the technical service staff provided by the product manufacturer noted for the design. Users of fire resistance assemblies are advised to consult the general Guide Information for each product category and each group of assemblies. The Guide Information includes specifics concerning alternate materials and alternate methods of construction.
- Only products which bear UL's Mark are considered Certified.

## BXUV - Fire Resistance Ratings - ANSI/UL 263

### BXUV7 - Fire Resistance Ratings - CAN/ULC-S101 Certified for Canada

See General Information for Fire-resistance Ratings - ANSI/UL 263

See General Information for Fire Resistance Ratings - CAN/ULC-S101 Certified for Canada

## Design No. V473

October 13, 2015

Nonbearing Wall Ratings — 1 or 2 Hr

\* Indicates such products shall bear the UL or cUL Certification Mark for jurisdictions employing the UL or cUL Certification (such as Canada), respectively.

### System A - 1 Hr.

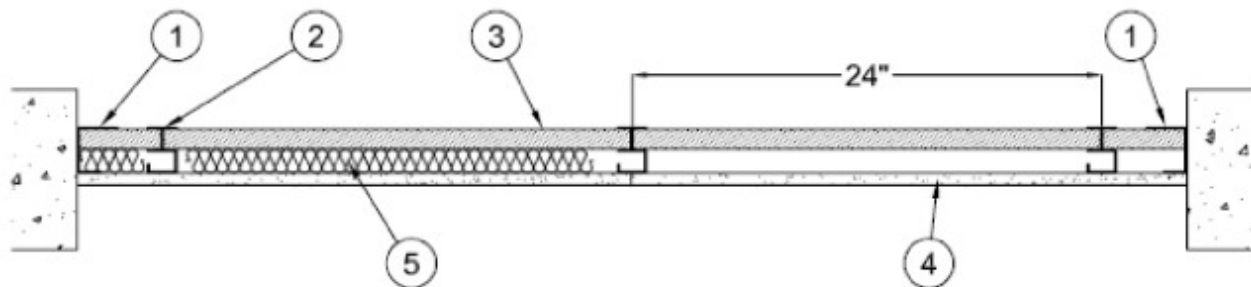

HORIZONTAL SECTION

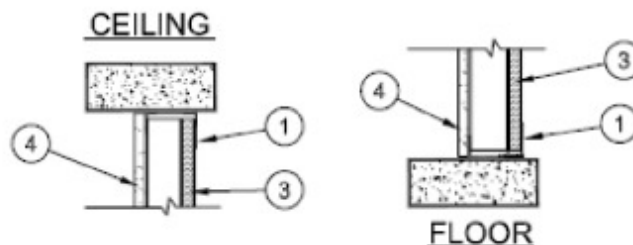

## System B - 2 Hr.

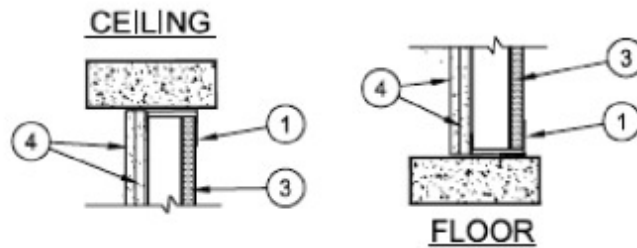
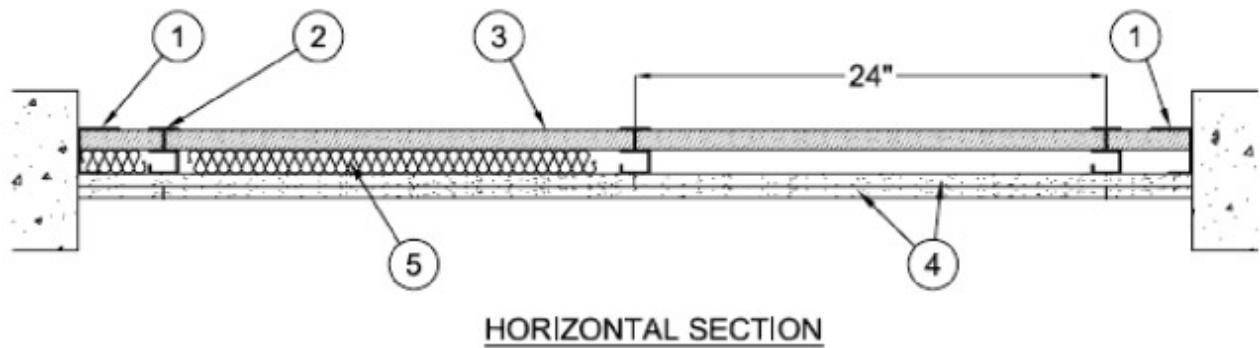

## System C - 2 Hr.

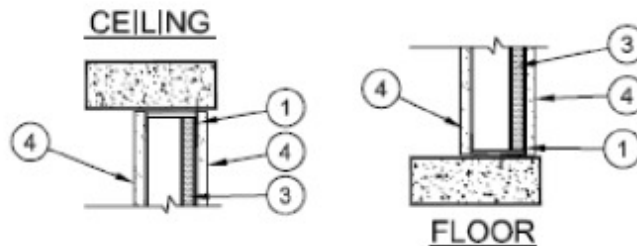
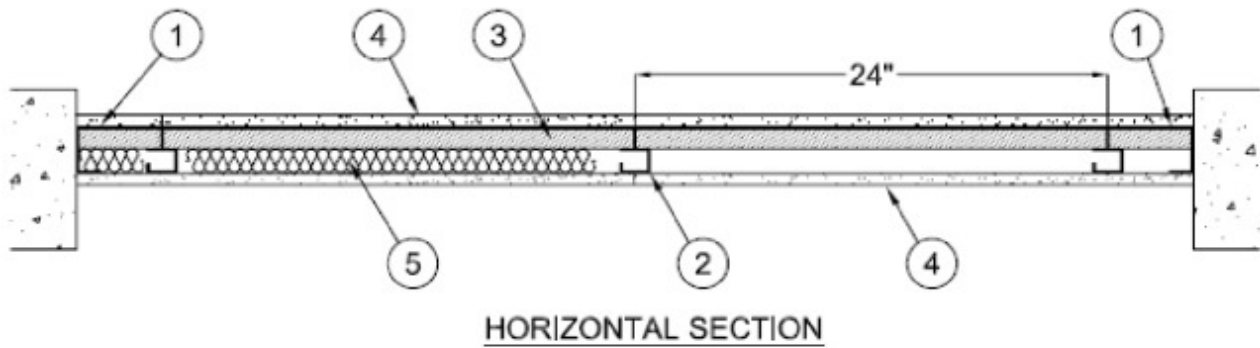

1. **Channel Track** — "J" -shaped channel, min. 2-1/2 in. deep with unequal legs of 1 in. and 2-1/4 in., fabricated from No. 25 MSG galv steel. Channel positioned with short leg toward finished side of wall. Channel attached to structural supports with steel fasteners located not greater than 2 in. from ends and not greater than 24 in. OC.

1A. **Steel Framing Members (Floor, Side and Ceiling Runners)\*** — As an alternate to Item 1. "J"-shaped runner, min 2-1/2 in. deep, with unequal legs of 1 in. and min 2-1/4 in. fabricated from min 25 MSG galv steel (0.0179 in. bare steel thickness). Runners positioned with short leg toward finished side of wall. Runners attached to structural supports with steel fasteners located not greater than 2 in. from ends and not greater than 24 in. OC. Runners may be supplied with securement tabs for gypsum liner panels (refer to Item 3).

**SCAFCO STEEL STUD MANUFACTURING CO** — I-Stud Shaftwall Steel Framing System

2. **Steel Studs** — "C-T" - shaped studs, min 2-1/2 in. deep, fabricated from min 25 MSG galv steel. Cut to lengths 1 in. less than floor to ceiling height and spaced 24 in. OC. Studs friction-fit into channel track.

2A. **Steel Studs** — "C-H" -shaped studs, min 2-1/2 in. deep, fabricated from min 25 MSG galv steel. Cut to lengths 1

in. less than floor to ceiling height and spaced 24 in. OC. Studs friction-fit into channel track.

**2B. Steel Framing Members (Steel Studs)\*** — As an alternate to Item 2. For use with Item 1A - "I"-shaped studs fabricated from min 25 MSG galv steel, min 2-1/2 in. deep, 1-1/2 in. wide. Studs contain 3/4 in. wide by 2-1/4 in. high holding tabs spaced 2-3/4 in. OC. Cut to lengths 5/8 in. less than floor-to-ceiling height and spaced 24 in.

**SCAFCO STEEL STUD MANUFACTURING CO** — I-Stud Shaftwall Steel Framing System

**2C. Furring Channels** — (Optional, Not Shown) — Resilient furring channels fabricated from min 25MSG corrosion protected steel, installed horizontally and spaced vertically a max of 24 in. OC. Flange portion of channel attached to each intersecting "C-T" or "C-H" stud on side of stud opposite the 1 in. liner panels using 1/2 in. long Type S or S-12 pan-head steel screws. When furring channels are used, gypsum board to be applied vertically.

**3. Gypsum Board\*** — 1 in. thick gypsum liner panels, supplied in nom 24 in. widths. Panels cut 1 in. less in length than floor to ceiling heights. Vertical edges inserted in "C-T" or "C-H" studs. Free edge of end panels attached to long leg of channel track with 1-5/8 in. long Type S self-drilling, self-tapping bugle head steel screws spaced 12 in. OC. As an alternate to attaching the free edge to the channel track, the free edge of the end panels may be held in place by the tabs in the channel track pulled out every 24 in. When wall height exceeds liner panel length, liner panel may be butted to extend to the full height of the wall, and the horizontal butt joints need not be backed by steel framing. When J-shaped runners (Item 1A) are supplied with securement tabs, free edge of end panels may be secured by bending the securement tabs, max 12 in. OC, to a 90 degree angle to securely friction-fit panels into J-shaped runners.

**GEORGIA-PACIFIC GYPSUM L L C** — Types DGUSL and TRSL

#### 4. Gypsum Board\* —

##### System A - 1 Hr

5/8 in. thick, 4 ft wide gypsum board applied horizontally or vertically. Vertical joints centered over studs. Attached to studs with 1 in. long Type S self-drilling, self-tapping bugle head steel screws spaced 8 in. OC along the edges and in the field of the boards. When furring channels (Item 2B) are used, board to be applied vertically and to be attached to furring channels with 1 in. long Type S self-drilling, self-tapping bugle head steel screws spaced max 8 in. OC. Joints covered with paper tape and joint compound. Exposed screw heads covered with joint compound.

**GEORGIA-PACIFIC GYPSUM L L C** — Types 6, 9, C, DAP, DAPC, DGG, DS, TG-C, Type X, Veneer Plaster Base - Type X, Water Rated - Type X, Sheathing - Type X, Soffit - Type X, Type LWX, Veneer Plaster Base-Type LWX, Water Rated-Type LWX, Sheathing Type-LWX, Soffit-Type LWX, Type DGLW, Water Rated-Type DGLW, Sheathing Type-DGLW, Soffit-Type DGLW, Type LW2X, Veneer Plaster Base - Type LW2X, Water Rated - Type LW2X, Sheathing - Type LW2X, Soffit - Type LW2X, Type DGL2W, Water Rated - Type DGL2W, Sheathing - Type DGL2W

##### System B - 2 Hr

5/8 in. thick, 4 ft wide gypsum board applied in two layers. Base layer applied horizontally or vertically, face layer applied vertically. Vertical joints centered over studs. Base layer attached to studs with 1 in. long Type S self-drilling, self-tapping bugle head steel screws spaced 24 in. OC along the edges and in the field of the boards. Face layer attached with 1-5/8 in. long Type S self-drilling, self-tapping bugle head steel screws spaced 12 in. OC along the top and bottom tracks and 12 in. OC in the field and along the vertical edges, staggered from screws in base layer. Joints between base and face layers staggered min. 24 in. When furring channels (Item 2B) are used, base layer to be applied vertically and to be attached to furring channels with 1 in. long Type S self-drilling, self-tapping bugle head steel screws spaced max 12 in. OC. Outer or face layer attached to furring channels with 1-5/8 in. long Type S self-drilling, self-tapping bugle head steel screws spaced 12 in. OC and staggered 6 in. from base layer screws. Joints between inner and outer layers staggered. Face layer joints covered with paper tape and joint compound. Exposed screw heads covered with joint compound.

**GEORGIA-PACIFIC GYPSUM L L C** — Types 6, 9, C, DAP, DAPC, DGG, DS, TG-C, Type X, Veneer Plaster Base - Type X, Water Rated - Type X, Sheathing - Type X, Soffit - Type X, Type LWX, Veneer Plaster Base-Type LWX, Water Rated-Type LWX, Sheathing Type-LWX, Soffit-Type LWX, Type DGLW, Water Rated-Type DGLW, Sheathing Type-DGLW, Soffit-Type DGLW, Type LW2X, Veneer Plaster Base - Type LW2X, Water Rated - Type LW2X, Sheathing - Type LW2X, Soffit - Type LW2X, Type DGL2W, Water Rated - Type DGL2W, Sheathing - Type DGL2W.

##### System C - 2 Hr

5/8 in. thick, 4 ft wide gypsum board applied vertically. Vertical joints centered over studs. Attached to studs with 1 in. long Type S self-drilling, self-tapping bugle head steel screws spaced 12 in. OC along the edges and in the field of the boards. When furring channels (Item 2B) are used, gypsum board to be applied vertically and to be attached to furring channels with 1 in. long Type S self-drilling, self-tapping bugle head steel screws spaced max 12 in. OC. Joints covered with paper tape and joint compound. Exposed screw heads covered with joint compound.

**GEORGIA-PACIFIC GYPSUM L L C** — Types 6, 9, C, DAP, DAPC, DGG, DS, TG-C, Type X, Veneer Plaster Base - Type X, Water Rated - Type X, Sheathing - Type X, Soffit - Type X, Type LWX, Veneer Plaster Base-Type LWX, Water Rated-Type LWX, Sheathing Type-LWX, Soffit-Type LWX, Type DGLW, Water Rated-Type DGLW, Sheathing Type-DGLW, Soffit-Type DGLW, Type LW2X, Veneer Plaster Base - Type LW2X, Water Rated - Type LW2X, Sheathing - Type LW2X, Soffit - Type LW2X, Type DGL2W, Water Rated - Type DGL2W, Sheathing - Type DGL2W.

5. **Batts and Blankets\*** — (Optional)-Mineral wool or glass fiber batts partially or completely filling stud cavity. Any mineral wool or glass fiber batt bearing the UL Classification Marking as to Fire Resistance. See **Batts and Blankets** (BZJZ) category for names of Classified companies.

**\* Indicates such products shall bear the UL or cUL Certification Mark for jurisdictions employing the UL or cUL Certification (such as Canada), respectively.**

Last Updated on 2015-10-13

---

[Questions?](#)

[Print this page](#)

[Terms of Use](#)

[Page Top](#)

© 2015 UL LLC

The appearance of a company's name or product in this database does not in itself assure that products so identified have been manufactured under UL's Follow-Up Service. Only those products bearing the UL Mark should be considered to be Certified and covered under UL's Follow-Up Service. Always look for the Mark on the product.

UL permits the reproduction of the material contained in the Online Certification Directory subject to the following conditions: 1. The Guide Information, Assemblies, Constructions, Designs, Systems, and/or Certifications (files) must be presented in their entirety and in a non-misleading manner, without any manipulation of the data (or drawings). 2. The statement "Reprinted from the Online Certifications Directory with permission from UL" must appear adjacent to the extracted material. In addition, the reprinted material must include a copyright notice in the following format: "© 2015 UL LLC".