



XHBN.HW-D-0631 Joint Systems

[Page Bottom](#)

Design/System/Construction/Assembly Usage Disclaimer

- Authorities Having Jurisdiction should be consulted in all cases as to the particular requirements covering the installation and use of UL Listed or Classified products, equipment, system, devices, and materials.
 - Authorities Having Jurisdiction should be consulted before construction.
 - Fire resistance assemblies and products are developed by the design submitter and have been investigated by UL for compliance with applicable requirements. The published information cannot always address every construction nuance encountered in the field.
 - When field issues arise, it is recommended the first contact for assistance be the technical service staff provided by the product manufacturer noted for the design. Users of fire resistance assemblies are advised to consult the general Guide Information for each product category and each group of assemblies. The Guide Information includes specifics concerning alternate materials and alternate methods of construction.
 - Only products which bear UL's Mark are considered as Classified, Listed, or Recognized.
-

Joint Systems

[See General Information for Joint Systems](#)

System No. HW-D-0631

September 16, 2010

Assembly Rating - 1 and 2 Hr (See Item 2)

Nominal Joint Width - 1/2 to 1 in.

L Rating At Ambient — Less than 1 CFM/Lin Ft

L Rating At 400°F — Less Than 1 CFM/Lin Ft

Class II and III Movement Capabilities — 100% Compression or Extension

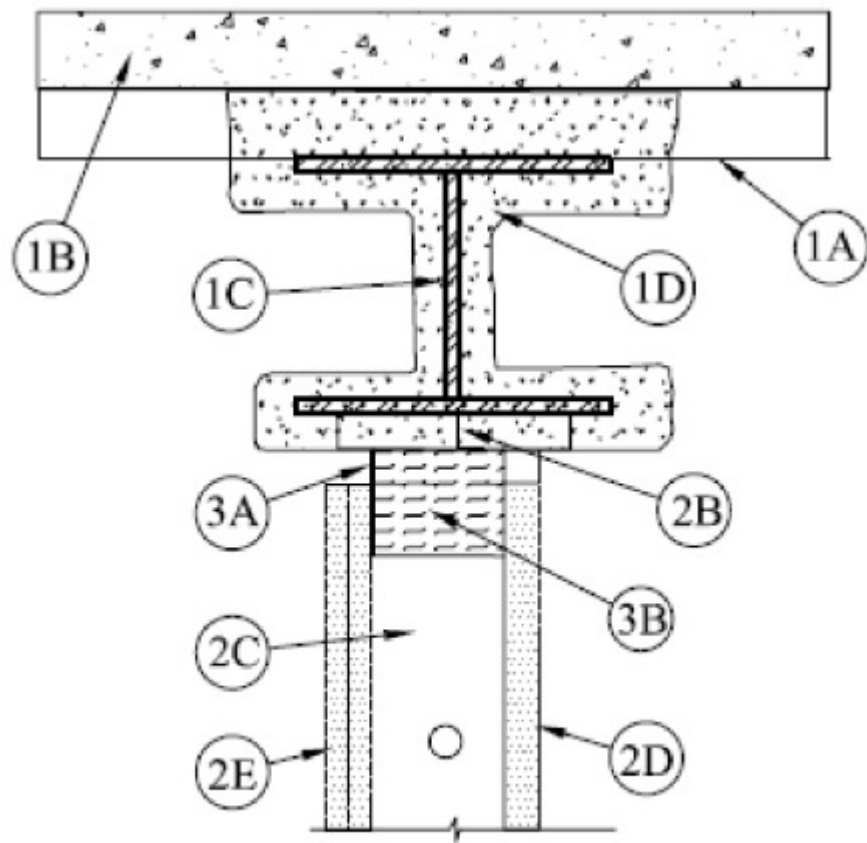

Configuration A

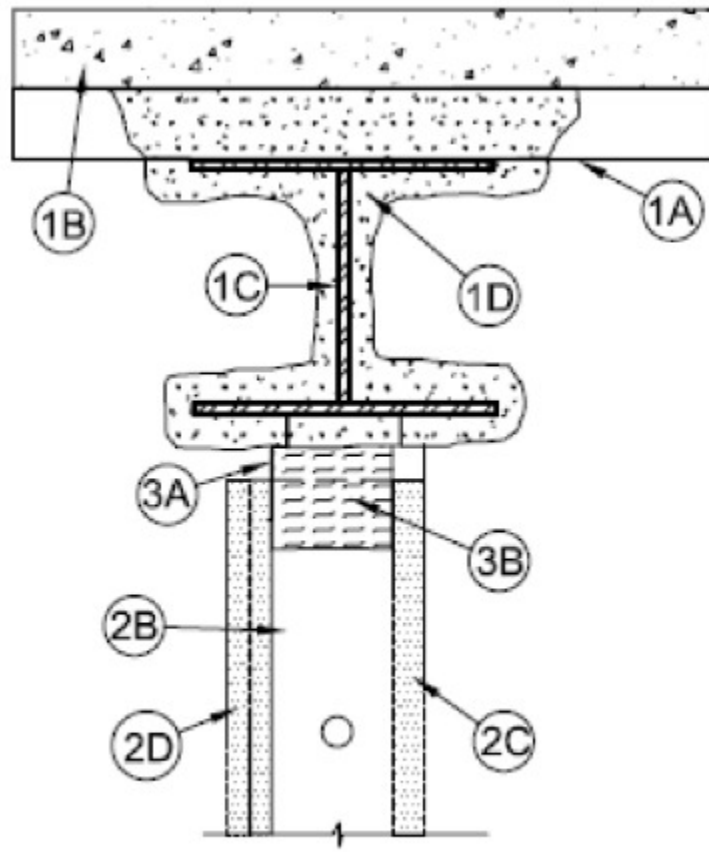

Configuration B

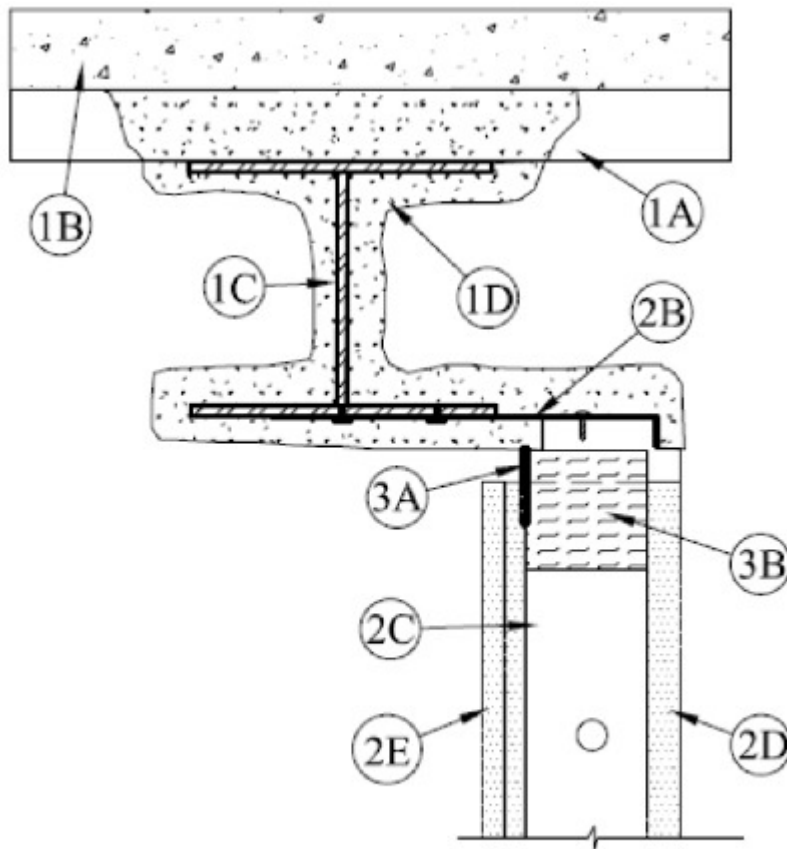

Configuration C

1. **Floor Assembly** — The fire-rated fluted steel deck/concrete floor assembly shall be constructed of the materials and in the manner described in the individual D700 or D900 Series Floor-Ceiling Design in the UL Fire Resistance Directory and shall include the following construction features:

- A. **Steel Floor And Form Units*** — Max 3 in. (76 mm) deep galv steel fluted floor units.
- B. **Concrete** — Min 2-1/2 in. (64 mm) thick reinforced concrete, as measured from the top plane of the floor units.
- C. **Structural Steel Support** — Steel beam, as specified in the individual D700 or D900 Series Floor-Ceiling Design, used to support steel floor units. Steel Beam installed parallel with wall assembly.
- D. **Spray-Applied Fire Resistive Material*** — After installation of the steel attachment clips (Item 2B, Configuration A) or Steel Plate (Item 2C, Configuration C), steel floor units and ceiling runner (Item 3), all surfaces of the structural steel support to be sprayed with the thickness of material specified in the individual D700 or D900 Series Floor-Ceiling Design. The flutes of the steel floor units are to be filled with material across the entire top flange of the steel beam. The areas between the bottom flange of the structural support and top of the ceiling runner are to be filled entirely with material and when steel plate (Item 2C) is used the top and bottom surfaces of steel plate to be sprayed with the min thickness of material specified in the individual N700 Series Design. The area above the stepped track legs are to be completely filled with the spray applied fire resistive material. Lower legs of ceiling runner and intumescent strips to be scraped clean after spray application. Additional material shall be applied to the web of the steel beam on each side of the wall. The thickness of material applied to each side of the steel beam web shall be 2 in. (51 mm).

ISOLATEK INTERNATIONAL — Type 300

W R GRACE & CO - CONN — Type MK-6/HY

Firestop Configuration A

2. **Wall Assembly** — The 1 hr or 2 hr fire rated gypsum board/steel stud shaft wall assembly shall be constructed of the materials and in the manner described in the individual U400 or V400 Series Wall and Partition Design in the UL Fire Resistance Directory and shall include the following construction features:

- A. **Steel Floor Runners** — (Not Shown) - The J-shaped or U-shaped steel channel floor runners are to

be sized to accommodate steel studs (Item 2B) and attached to floor with steel fasteners located not greater than 2 in. (51 mm) from ends and not greater than 24 in. (610 mm) OC.

B. Steel Attachment Clips — Z-shaped clips formed from 1 in. (25 mm) wide strips of min 20 ga galv steel. Clips sized to extend through the thickness of the spray-applied fire resistive material on the bottom flange of the steel beam with 1-1/2 in. (38 mm) long upper and lower legs. Legs of clips fastened to bottom of beam (prior to application of spray-applied fire-resistive materials) and top of ceiling runner with steel fasteners or welds. Clips spaced max 16 in. (406 mm) OC.

C. Studs — "C-T", "I", or "C-H" shaped steel studs to be min 2 1/2 in. (64 mm) wide and formed of min 24 ga galv steel. Studs cut 1/2 in. to 3/4 in. (13 to 19 mm) less in length than floor-to-ceiling height as measured to shoulder of ceiling runner (Item 3A) with bottom nesting in and secured to floor runner. Studs to nest in ceiling runner (Item 3A) without attachment. Studs spaced 24 in. (610 mm) OC.

D. Gypsum Board* — Nom 1 in. (25 mm) thick by 24 in. (610 mm) wide gypsum board liner panels applied on unfinished side of wall. Panels cut 1 in. to 1-1/2 in. (25 to 38 mm) less in length than floor-to-ceiling height as measured to shoulder of ceiling runner (Item 3A). Vertical edges inserted into "T" shaped section of "C-T" studs, into holding tabs of "I" studs or into "H"-shaped section of "C-H" studs.

E. Gypsum Board* — Nom 1/2 or 5/8 in. (13 or 16 mm) thick gypsum board sheets applied on finished side of wall as specified in the individual Wall and Partition Design. Boards cut 3/8 in. (10 mm) to 3/4 in. (19 mm) less in length than the floor to ceiling height below **Spray Applied Fire Resistive Material***. The screws attaching the gypsum board layer(s) to the "C-T", "I", or "C-H" studs shall be located 1-1/2 in. (38 mm) below the bottom of the ceiling runner legs. No gypsum board attachment screws shall be driven into the ceiling runner.

The hourly fire rating of the joint system is equal to the hourly fire rating of the wall.

3. Joint System — Max separation between bottom of Spray Applied Fire Resistive Material on steel deck and top of gypsum board on finished side of wall (at time of installation) is 3/8 to 3/4 in. (10 to 19 mm). The joint system is designed to accommodate a max 100 percent compression from its installed width.

A1. Fill, Void or Cavity Material* — For nom 3/8 in. (10 mm) joints, a nom 20 ga J-shaped track having one solid 2 in. leg and one solid 3 in (51 and 76 mm) leg or a nom 20 ga J-shaped track having one 2 in. (51 mm) solid leg and one 3 in. (76 mm) slotted leg with a nom 1 in. (25 mm) wide intumescent strip is to be located on the finished side of wall. Gypsum board to overlap a min of 5/8 in. (16 mm) over the intumescent strip. Ceiling runner attached to steel clips (Item 2B) with steel fasteners or welds spaced max 24 in. (610 mm) OC.

JAK INNOVATIONS — BlazeFrame JR1 or SL1 series.

A2. Fill, Void or Cavity Material* — For nom 1/2 in. (13 mm) joints, a nom 20 ga J-shaped track having one solid 2 in. leg and one solid 3 in (51 or 76 mm) leg or a nom 20 ga J-shaped track having one 2 in. (51 mm) solid leg and one 3 in. (76 mm) slotted leg, with a nom 1-1/4 in. (32 mm) wide intumescent strip and is to be located on the finished side of wall. Gypsum board to overlap min 3/4 in. (19 mm) over the intumescent strip. Ceiling runner attached to steel clips (Item 2B) with steel fasteners or welds spaced a max 24 in. (610 mm) OC.

JAK INNOVATIONS — BlazeFrame JRW1 or SLW1 series

A3. Fill, Void or Cavity Material* — For nom 3/4 in. (19 mm) joints, a nom 20 ga J-shaped track having one solid 2 in. leg and one solid 3 in (51 or 76 mm) leg or a nom 20 ga J-shaped track having one 2 1/2 in. (63 mm) solid leg and one 4 in. (102 mm) slotted leg, with a nom 1-3/4 in. (44 mm) wide intumescent strip, is to be located on the finished side of wall. Gypsum board to overlap min 1 in. (25 mm) over the intumescent strip. Ceiling runner attached to steel clips (Item 2B) with steel fasteners or welds spaced a max 24 in. (610 mm) OC.

JAK INNOVATIONS — BlazeFrame JRX1 or SLX1

B. Forming Material — Min 4 in. (102 mm) thickness of min 4 pcf (64 kg/m³) mineral wool batt insulation cut to the width of the ceiling runner and compressed 33 percent in thickness, installed into ceiling runner between leg of track and gypsum liner board.

FIBREX INSULATIONS INC — FBX Safing Insulation

IIG MINWOOL L L C — MinWool-1200 Safing

ROCK WOOL MANUFACTURING CO — Delta Board

ROXUL INC — Safe

THERMAFIBER INC — SAF

Firestop Configuration B

2. **Wall Assembly** — The 1 hr or 2 hr fire rated gypsum board/steel stud shaft wall assembly shall be constructed of the materials and in the manner described in the individual U400 or V400 Series Wall and Partition Design in the UL Fire Resistance Directory and shall include the following construction features:

A. **Steel Floor Runners** — (Not Shown) - The J-shaped or U-shaped steel channel floor runners are to be sized to accommodate steel studs (Item 2B) and attached to floor with steel fasteners located not greater than 2 in. (51 mm) from ends and not greater than 24 in. (610 mm) OC.

B. **Studs** — "C-T", "I", or "C-H" shaped steel studs to be min 2 1/2 in. (64 mm) wide and formed of min 24 ga galv steel. Studs cut 1/2 in. to 3/4 in. (13 to 19 mm) less in length than floor-to-ceiling height as measured to shoulder of ceiling runner (Item 3A) with bottom nesting in and secured to floor runner. Studs to nest in ceiling runner (Item 3A) without attachment. Studs spaced 24 in. (610 mm) OC.

C. **Gypsum Board*** — Nom 1 in. (25 mm) thick by 24 in. (610 mm) wide gypsum board liner panels applied on unfinished side of wall. Panels cut 1 in. to 1-1/2 in. (25 to 38 mm) less in length than floor-to-ceiling height as measured to shoulder of ceiling runner (Item 3A). Vertical edges inserted into "T" shaped section of "C-T" studs, into holding tabs of "I" studs or into "H"-shaped section of "C-H" studs.

D. **Gypsum Board*** — Nom 1/2 or 5/8 in. (13 or 16 mm) thick gypsum board sheets applied on finished side of wall as specified in the individual Wall and Partition Design. Boards cut 3/8 in. (10 mm) to 3/4 in. (19 mm) less in length than the floor to ceiling height below **Spray Applied Fire Resistant Material***. The screws attaching the gypsum board layer(s) to the "C-T", "I", or "C-H" studs shall be located 1-1/2 in. (38 mm) below the bottom of the ceiling runner legs. No gypsum board attachment screws shall be driven into the ceiling runner.

The hourly fire rating of the joint system is equal to the hourly fire rating of the wall.

3. **Joint System** — Max separation between bottom of Spray Applied Fire Resistant Material on steel deck and top of gypsum board on finished side of wall (at time of installation) is 3/8 to 3/4 in. (10 to 19 mm). The joint system is designed to accommodate a max 100 percent compression from its installed width.

A1. **Fill, Void or Cavity Material*** — For nom 3/8 in. (10 mm) joints, a stepped-leg galv steel channel track having unequal legs with the height of the upper portion of track legs equal to or greater than the required thickness of **Spray Applied Fire Resistant Material*** on steel roof deck. Lower portion of shorter track leg is provided with a nom 1 in. (25 mm) wide intumescent strip and is to be located on the finished side of wall. Gypsum board (Item 2C) to overlap min 5/8 in. (16 mm) over the lower edge of the intumescent strips. Track attached to steel beam with steel fasteners or welds spaced a max of 24 in. (610 mm) OC.

JAK INNOVATIONS — BlazeFrame OJR1 series

A2. **Fill, Void or Cavity Material*** — For nom 1/2 in. (13 mm) joints, a stepped-leg galv steel channel track having unequal legs with the height of the upper portion of track legs equal to or greater than the required thickness of **Spray Applied Fire Resistant Material*** on steel roof deck. Lower portion of shorter track leg is provided with a nom 1-1/4 in. (32 mm) wide intumescent strip and is to be located on the finished side of wall. Gypsum board (Item 2C) to overlap min 3/4 in. (19 mm) over the lower edge of the intumescent strips. Track attached to steel beam with steel fasteners or welds spaced a max of 24 in. (610 mm) OC.

JAK INNOVATIONS — BlazeFrame OJRW1 series

A3. **Fill, Void or Cavity Material*** — For nom 3/4 in. (19 mm) joints, a stepped-leg galv steel channel track having unequal legs with the height of the upper portion of track legs equal to or greater than the required thickness of **Spray Applied Fire Resistant Material*** on steel roof deck. Lower portion of shorter track leg is provided with a nom 1-3/4 in. (45 mm) wide intumescent strip and is to be located on the finished side of wall. Gypsum board (Item 2C) to overlap min 1 in. (25 mm) over the lower edge of the intumescent strips. Track attached to steel beam with steel fasteners or welds spaced a max of 24 in. (610 mm) OC.

JAK INNOVATIONS — BlazeFrame OJRX1 series

B. **Forming Material** — Min 4 in. (102 mm) thickness of min 4 pcf (64 kg/m³) mineral wool batt

insulation cut to the width of the ceiling runner and compressed 33 percent in thickness, installed into ceiling runner between leg of track and gypsum liner board.

FIBREX INSULATIONS INC — FBX Safing Insulation

IIG MINWOOL L L C — MinWool-1200 Safing

ROCK WOOL MANUFACTURING CO — Delta Board

ROXUL INC — Safe

THERMAFIBER INC — SAF

Firestop Configuration C

2. **Wall Assembly** — The 1 hr or 2 hr fire rated gypsum board/steel stud shaft wall assembly shall be constructed of the materials and in the manner described in the individual U400 or V400 Series Wall and Partition Design in the UL Fire Resistance Directory and shall include the following construction features:

A. **Steel Floor Runners** — (Not Shown) - The J-shaped or U-shaped steel channel floor runners are to be sized to accommodate steel studs (Item 2B) and attached to floor with steel fasteners located not greater than 2 in. (51 mm) from ends and not greater than 24 in. (610 mm) OC.

B. **Steel Plate** — Min 14ga (0.067 in or 1.7 mm thick) steel plate lapping min 1 1/2 in. (38 mm) onto bottom of steel beam flange and fastened to beam with typical steel fasteners or welds max 16 in. (406 mm) OC. Angle to extend beyond one side of beam for attachment of stepped ceiling runner (Item 3) with typical steel fasteners. Innermost flange of stepped ceiling runner to be parallel with and located max 8 in. (203 mm) from the edge of the steel beam flange.

C. **Studs** — "C-T", "I", or "C-H" shaped steel studs to be min 2 1/2 in. (64 mm) wide and formed of min 24 ga galv steel. Studs cut 1/2 in. to 3/4 in. (13 to 19 mm) less in length than floor-to-ceiling height as measured to shoulder of ceiling runner (Item 3A) with bottom nesting in and secured to floor runner. Studs to nest in ceiling runner (Item 3A) without attachment. Studs spaced max 24 in. (610 mm) OC.

D. **Gypsum Board*** — Nom 1 in. (25 mm) thick by 24 in. (610 mm) wide gypsum board liner panels applied on unfinished side of wall. Panels cut 1 in. to 1-1/2 in. (25 to 38 mm) less in length than floor-to-ceiling height as measured to shoulder of ceiling runner (Item 3A). Vertical edges inserted into "T" shaped section of "C-T" studs, into holding tabs of "I" studs or into "H"-shaped section of "C-H" studs.

E. **Gypsum Board*** — Nom 1/2 or 5/8 in. (13 or 16 mm) thick gypsum board sheets applied on finished side of wall as specified in the individual Wall and Partition Design. Boards cut 3/8 in. (10 mm) to 3/4 in. (19 mm) less in length than the floor to ceiling height below **Spray Applied Fire Resistive Material***. The screws attaching the gypsum board layer(s) to the "C-T", "I", or "C-H" studs shall be located 1-1/2 in. (38 mm) below the bottom of the ceiling runner legs. No gypsum board attachment screws shall be driven into the ceiling runner.

The hourly fire rating of the joint system is equal to the hourly fire rating of the wall.

3. **Joint System** — Max separation between bottom of Spray Applied Fire Resistive Material on steel deck and top of gypsum board on finished side of wall (at time of installation) is 3/8 to 3/4 in. (10 to 19 mm). The joint system is designed to accommodate a max 100 percent compression from its installed width.

A1. **Fill, Void or Cavity Material*** — For nom 3/8 in. (10 mm) joints, a stepped-leg galv steel channel track having unequal legs with the height of the upper portion of track legs equal to or greater than the required thickness of **Spray Applied Fire Resistive Material*** on steel roof deck. Lower portion of shorter track leg is provided with a nom 1 in. (25 mm) wide intumescent strip and is to be located on the finished side of wall. Gypsum board (Item 2C) to overlap min 5/8 in. (16 mm) over the lower edge of the intumescent strips. Track attached to steel plate with steel fasteners or welds spaced a max of 24 in. (610 mm) OC.

JAK INNOVATIONS — BlazeFrame OJR1 series

A2. **Fill, Void or Cavity Material*** — For nom 1/2 in. (13 mm) joints, a stepped-leg galv steel channel track having unequal legs with the height of the upper portion of track legs equal to or greater than the required thickness of **Spray Applied Fire Resistive Material*** on steel roof deck. Lower portion of shorter track leg is provided with a nom 1-1/4 in. (32 mm) wide intumescent strip and is to be located on the finished side of wall. Gypsum board (Item 2C) to overlap min 3/4 in. (19 mm) over the lower edge of the intumescent strips. Track attached to steel plate with steel fasteners or welds spaced a max of 24 in.

(610 mm) OC.

JAK INNOVATIONS — BlazeFrame OJRW1 series

A3. **Fill, Void or Cavity Material*** — For nom 3/4 in. (19 mm) joints, a stepped-leg galv steel channel track having unequal legs with the height of the upper portion of track legs equal to or greater than the required thickness of **Spray Applied Fire Resistive Material*** on steel roof deck. Lower portion of shorter track leg is provided with a nom 1-3/4 in. (45 mm) wide intumescent strip and is to be located on the finished side of wall. Gypsum board (Item 2C) to overlap min 1 in. (25 mm) over the lower edge of the intumescent strips. Track attached to steel plate with steel fasteners or welds spaced a max of 24 in. (610 mm) OC.

JAK INNOVATIONS — BlazeFrame OJRX1 series

B. **Forming Material** — Min 4 in. (102 mm) thickness of min 4 pcf (64 kg/m³) mineral wool batt insulation cut to the width of the ceiling runner and compressed 33 percent in thickness, installed into ceiling runner between leg of track and gypsum liner board.

FIBREX INSULATIONS INC — FBX Safing Insulation

IIG MINWOOL L L C — MinWool-1200 Safing

ROCK WOOL MANUFACTURING CO — Delta Board

ROXUL INC — Safe

THERMAFIBER INC — SAF

*Bearing the UL Classification Mark

Last Updated on 2010-09-16

[Questions?](#)

[Print this page](#)

[Notice of Disclaimer](#)

[Page Top](#)

[Copyright © 2010 Underwriters Laboratories Inc.®](#)

The appearance of a company's name or product in this database does not in itself assure that products so identified have been manufactured under UL's Follow-Up Service. Only those products bearing the UL Mark should be considered to be Listed and covered under UL's Follow-Up Service. Always look for the Mark on the product.

UL permits the reproduction of the material contained in the Online Certification Directory subject to the following conditions: 1. The Guide Information, Designs and/or Listings (files) must be presented in their entirety and in a non-misleading manner, without any manipulation of the data (or drawings). 2. The statement "Reprinted from the Online Certifications Directory with permission from Underwriters Laboratories Inc." must appear adjacent to the extracted material. In addition, the reprinted material must include a copyright notice in the following format: "Copyright © 2010 Underwriters Laboratories Inc.®"

An independent organization working for a safer world with integrity, precision and knowledge.

