



XHBN.HW-D-0599 Joint Systems

[Page Bottom](#)

Design/System/Construction/Assembly Usage Disclaimer

- Authorities Having Jurisdiction should be consulted in all cases as to the particular requirements covering the installation and use of UL Listed or Classified products, equipment, system, devices, and materials.
 - Authorities Having Jurisdiction should be consulted before construction.
 - Fire resistance assemblies and products are developed by the design submitter and have been investigated by UL for compliance with applicable requirements. The published information cannot always address every construction nuance encountered in the field.
 - When field issues arise, it is recommended the first contact for assistance be the technical service staff provided by the product manufacturer noted for the design. Users of fire resistance assemblies are advised to consult the general Guide Information for each product category and each group of assemblies. The Guide Information includes specifics concerning alternate materials and alternate methods of construction.
 - Only products which bear UL's Mark are considered as Classified, Listed, or Recognized.
-

Joint Systems

[See General Information for Joint Systems](#)

System No. HW-D-0599

September 22, 2010

Assembly Rating — 2 Hr

Nominal Joint Width — 1 in.

Class II and III Movement Capabilities — 100% Compression or Extension

L Rating at Ambient — Less than 1 CFM/Lin Ft

L Rating at 400°F — Less than 1 CFM/Lin Ft

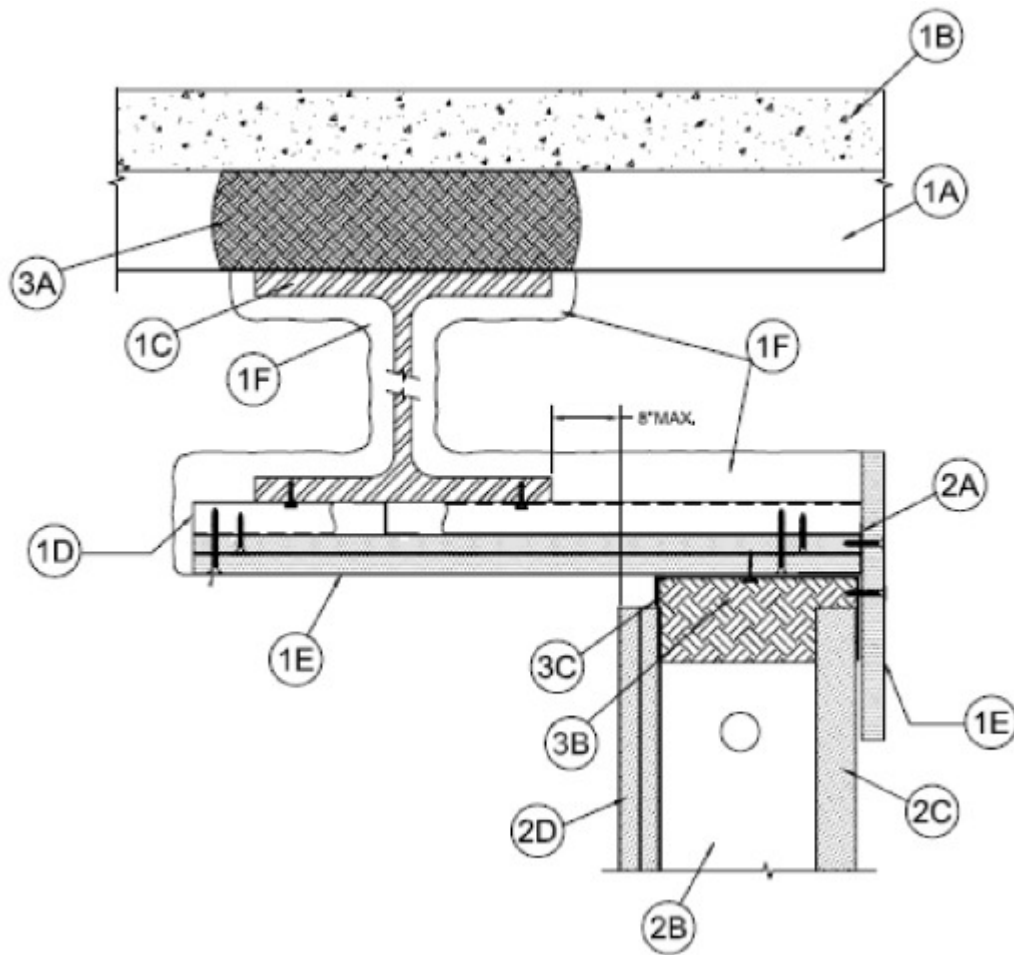

1. **Floor Assembly** — The fire-rated fluted steel deck/concrete floor assembly shall be constructed of the materials and in the manner described in the individual D700 or D900 Series Floor-Ceiling Design in the UL Fire Resistance Directory and shall include the following construction features:

A. **Steel Floor And Floor Units*** — Max 3 in. (76 mm) deep galv steel fluted floor units.

B. **Concrete** — Min 2-1/2 in. (64 mm) thick reinforced concrete, as measured from the top plane of the floor units.

C. **Structural Steel Support** — Steel beam, as specified in the individual D700 or D900 Series Floor-Ceiling Design, used to support steel floor units. Structural steel support oriented parallel to and 8 in. (203 mm) max from wall assembly.

D. **Steel Attachment Clips** — 1 in. (25 mm) wide Z-shaped clips or channels formed from min 16 ga galv or painted steel. Clips to be sized to extend through the thickness of the spray-applied fire-resistive material on the bottom flange of the steel beam with 1-1/2 in. (38 mm) long upper and lower legs. Legs of clips fastened to bottom of beam (prior to application of spray-applied fire-resistive materials) with min two steel fasteners or welds and to ceiling runner of wall with bolts or screws. Clips spaced max 16 in. (406 mm) OC and extend from steel support beam to flush with non-beam face of wall.

E. **Gypsum Board*** — Two layers of 5/8 in. (16 mm) thick glass mat faced (moisture resistant) gypsum board applied to bottom of steel attachment clips. The boards are cut to the length of steel attachment clips and secured to each clip. Base layer attached to the clips using 1 in. (25 mm) long Type S bugle-head steel screws spaced 12 in. (305 mm) OC, 1 in. (25 mm) max from ends. Outer layer attached to the clips using 1-5/8 in. (41 mm) long Type S bugle-head steel screws spaced 12 in. (305 mm) OC, 1 in. (25 mm) max from ends. Butted joints are centered over clips and joints in base and outer layers to be offset. Joints and screw heads in outer layer covered with two coats of joint compound.

See **Gypsum Board** (CKNX) Category for names of Classified Companies of 5/8 in. (16 mm) thick board.

F. **Spray-Applied Fire Resistive Material*** — After installation of the steel attachment clips, structural steel support, and steel floor units (as applicable), to be sprayed with the min thickness of material specified in the individual D700 or D900 Series Design. Each steel attachment clip to be fully covered with spray applied fire resistive material to the minimum thickness of material required on the flanges of the steel beam and the spaces between the clips shall also be fully filled from beam and over the entire thickness of the wall. Additional material shall be applied to the web of steel beam on each side of wall. The min total thickness of material applied to each side of steel beam web shall be 1-1/2 in. (38 mm). When Item 3A is not used, the flutes of the steel floor units are to be filled with material across the entire top flange of the steel beam. For D700 floors, the remainder of the steel floor units shall be sprayed as

specified in the individual D700 design.

ISOLATEK INTERNATIONAL — Type 300

W R GRACE & CO - CONN — Type MK-6/HY

1A. Roof Assembly — (Not Shown) — As an alternate to the floor assembly, a fire-rated fluted steel deck roof assembly may be used. The roof assembly shall be constructed of the materials and in the manner described in the individual P700 or P900 Series Roof-Ceiling Design in the UL Fire Resistance Directory. The roof assembly shall include the following construction features:

A. **Steel Roof Deck** — Max 3 in. (76 mm) deep galv steel fluted roof deck.

B. **Roof Insulation** — Min 2-1/4 in. (57 mm) thick poured insulating concrete, as measured from the top plane of the roof deck.

C. **Structural Steel Support** — Steel beam, as specified in the individual P700 or P900 Series Design, used to support steel floor units. Structural steel support oriented parallel to and 8 in. (203 mm) max from wall assembly.

D. **Steel Attachment Clips** — 1 in. (25 mm) wide Z-shaped clips or channels formed from min 16 ga galv or painted steel. Clips to be sized to extend through the thickness of the spray-applied fire-resistive material on the bottom flange of the steel beam with 1-1/2 in. (38 mm) long upper and lower legs. Legs of clips fastened to bottom of beam (prior to application of spray-applied fire-resistive materials) with min two steel fasteners or welds and to ceiling runner of wall with bolts or screws. Clips spaced max 16 in. (406 mm) OC and extend from steel support beam to flush with non-beam face of wall.

E. **Gypsum Board*** — Two layers of 5/8 in. (16 mm) thick glass mat faced (moisture resistant) gypsum board applied to bottom of steel attachment clips. The boards are cut to the length of steel attachment clips and secured to each clip. Base layer attached to the clips using 1 in. (25 mm) long Type S bugle-head steel screws spaced 12 in. (305 mm) OC, 1 in. (25 mm) max from ends. Outer layer attached to the clips using 1-5/8 in. (41 mm) long Type S bugle-head steel screws spaced 12 in. (305 mm) OC, 1 in. (25 mm) max from ends. Butted joints are centered over clips and joints in base and outer layers to be offset. Joints and screw heads in outer layer covered with two coats of joint compound. An additional nominal 9 in. (229 mm) wide strip of gypsum board covering the exposed leg of the ceiling runner attached to the ceiling runner and to the 1-1/2 by 1-1/2 in. (38 by 38 mm) galv steel angle (see Item 2A) with min 1 in. (25 mm) long fasteners spaced a max of 12 in. (305 mm) on center and 1 in. (25 mm) max from ends along track and angle on the non-finished side of wall. This strip of gypsum shall extend above the ceiling track to be flush with top of spray applied fire resistive material on steel attachment clips, and the strip shall extend down min 1-1/2 in. (38 mm) below the exposed leg of ceiling track.

See **Gypsum Board** (CKNX) Category for names of Classified Companies of 5/8 in. (16 mm) thick board.

F. **Spray-Applied Fire Resistive Material*** — After installation of the steel attachment clips, structural steel support, and roof deck (as applicable), to be sprayed with the min thickness of material specified in the individual P700 or P900 Series Design. Each steel attachment clip to be fully covered with spray applied fire resistive material to the minimum thickness of material required on the flanges of the steel beam and the spaces between the clips shall also be fully filled from beam and over the entire thickness of the wall. Additional material shall be applied to the web of steel beam on each side. The min total thickness of material applied to each side of steel beam web shall be 1-1/2 in. (38 mm). When Item 3A is not used, the flutes of the roof deck are to be filled with material across the entire top flange of the steel beam. For P700 roof-ceiling assemblies, the remainder of the roof deck shall be sprayed as specified in the individual P700 design.

ISOLATEK INTERNATIONAL — Type 300

W R GRACE & CO - CONN — Type MK-6/HY

1B. Floor Assembly — (Not Shown) — Min 4-1/2 in. thick reinforced lightweight or normal weight (100 to 150 pcf) structural concrete.

2. Shaft Wall Assembly — The 2 hr fire rated gypsum board/stud wall assembly shall be constructed of the materials and in the manner described in the individual U400 or V400 Series Wall and Partition Design in the UL Fire Resistance Directory and shall include the following construction features:

A. **Steel Floor and Ceiling Runners** — Floor runner U-shaped, sized to accommodate steel studs (Item 2B), fabricated from 25 ga galv steel. Ceiling runner positioned with slotted leg toward finished side of wall. Runners attached to steel attachment clips through gypsum board (Item 1E) with min 2 in. (51 mm) long steel fasteners, minimum one fastener per clip. The ceiling runners are provided with a fill, void or cavity material and are described in Item 3. A nom 1-1/2 by 1-1/2 in. (38 by 38 mm) galvanized steel angle shall be attached to top of ceiling runner on non-beam side of wall with No. 8 sheet metal

screws spaced 16 in. (406 mm) max on center and 1 in. (25 mm) max from ends.

B. **Studs** — "C-T", "I", or "C-H" shaped steel studs to be min 2 1/2 in. (64 mm) wide and formed of min 25 ga galv steel. Studs cut 1 to 1-1/4 in (25 to 32 mm) less in length than assembly height with bottom nesting in and secured to floor runner. Steel studs secured to slotted leg of ceiling runner on finished side with No. 8 by 1/2 (13 mm) long wafer head steel screws at mid-height of exposed slot. Studs spaced max 24 in. (610 mm) OC.

C. **Gypsum Board*** — 1 in. (25 mm) thick by max 24 in. (610 mm) wide gypsum board liner panels. Panels cut 1-1/2 in. (38 mm) less in length than floor to ceiling height. Vertical edges inserted into "T" shaped section of "C-T" studs, into holding tabs of "I" studs or into "H"-shaped section of "C-H" studs.

D. **Gypsum Board*** — Gypsum board 1/2 or 5/8 in. (13 or 16 mm) thick, applied on finished side of wall as specified in the individual Wall and Partition Design. The boards cut a max 1 in. (25 mm) less in length than the floor to ceiling height. The screws attaching the gypsum board layer(s) to the "C-T", "I", or "C-H" studs shall be located 4 to 5 in. (102 to 127 mm) down from deck at time of installation.

3. Joint System — Max separation between bottom of floor or roof deck or spray-applied fire resistive material on steel floor or roof unit and top of wall (at time of installation of joint system) is 1 in. (25 mm). The joint system is designed to accommodate a max 100 percent compression or extension from its installed width.

A. **Forming Material*** — Min 4 pcf (64 kg/m³) mineral wool insulation cut to the shape of the fluted steel floor or roof deck units, approx 33% larger than the area of the flutes. Pieces compressed and inserted into and completely filling the flutes above the structural support member. As an option, the spray-applied fire resistive material described in Item 1 can be used in place of the packing material.

B. **Forming Material*** — Min 4 in. (102 mm) thick strips of min 4 pcf (64 kg/m³) mineral wool batt insulation cut to the width of the ceiling runner and tightly friction fit into ceiling runner between leg of track and gypsum liner board to completely fill cavity within ceiling runner.

C. **Fill, Void or Cavity Material*** — Nom 20 ga U-shaped track having 3 in (76 mm) legs with a nom 2-1/2 in. (64 mm) wide intumescent strip affixed to the top of the leg overlapping on to top surface a min of 1/4 in. (6 mm) facing the finished side of wall. Track to be secured through gypsum board material to steel attachment clips with min 2 in. (51 mm) long steel fasteners spaced at a max of 16 in. (406 mm) OC (min one fastener into each clip).

CALIFORNIA EXPANDED METAL PRODUCTS CO — FAS SHAFT Track DL2

*Bearing the UL Classification Mark

Last Updated on 2010-09-22

[Questions?](#)

[Print this page](#)

[Notice of Disclaimer](#)

[Page Top](#)

[Copyright © 2010 Underwriters Laboratories Inc.®](#)

The appearance of a company's name or product in this database does not in itself assure that products so identified have been manufactured under UL's Follow-Up Service. Only those products bearing the UL Mark should be considered to be Listed and covered under UL's Follow-Up Service. Always look for the Mark on the product.

UL permits the reproduction of the material contained in the Online Certification Directory subject to the following conditions: 1. The Guide Information, Designs and/or Listings (files) must be presented in their entirety and in a non-misleading manner, without any manipulation of the data (or drawings). 2. The statement "Reprinted from the Online Certifications Directory with permission from Underwriters Laboratories Inc." must appear adjacent to the extracted material. In addition, the reprinted material must include a copyright notice in the following format: "Copyright © 2010 Underwriters Laboratories Inc.®"

An independent organization working for a safer world with integrity, precision and knowledge.

