



ICC Evaluation Service, Inc.
www.icc-es.org

Business/Regional Office ■ 5360 Workman Mill Road, Whittier, California 90601 ■ (562) 699-0543
Regional Office ■ 900 Montclair Road, Suite A, Birmingham, Alabama 35213 ■ (205) 599-9800
Regional Office ■ 4051 West Flossmoor Road, Country Club Hills, Illinois 60478 ■ (708) 799-2305

Legacy report on the 1997 Uniform Building Code™

DIVISION: 09—THERMAL AND MOISTURE PROTECTION
Section: 09260—Gypsum Board Assemblies

EVALUATION SUBJECT:

PROROC® GYPSUM SHAFTWALL SYSTEMS

CERTAINTEED GYPSUM, INC
4300 WEST CYPRESS STREET
SUITE 500
TAMPA, FLORIDA 33607

ADDITIONAL LISTEES:

DIETRICH INDUSTRIES, INC.
500 GRANT STREET, SUITE 2226
PITTSBURGH, PENNSYLVANIA 15219

PHILLIPS MANUFACTURING COMPANY
4404 SOUTH 76TH CIRCLE
OMAHA, NEBRASKA 68127

SCAFCO CORPORATION
6200 EAST MAIN AVENUE
SPOKANE, WASHINGTON 99211

1.0 SUBJECT

One- and Two-hour Fire-resistive ProRoc® Gypsum Shaftwall Systems.

2.0 DESCRIPTION

2.1 General:

CertainTeed Gypsum, Inc. shaftwall partition systems are designed for use where one- and two-hour, fire-resistive, nonload-bearing wall assemblies are required. The partitions may be erected from one side and left unfinished on the service equipment or shaft side, or they may be finished on both sides when used to enclose staircases or other occupied areas. The systems consist of CertainTeed Gypsum, Inc. 1-inch-thick (25.4 mm) ProRoc® Shaftliner, and 1/2-inch-thick (12.7 mm) ProRoc® Type C, or 5/8-inch-thick (15.9 mm) ProRoc® Type X gypsum wallboard ; supported by either SCAFCO Corporation or Phillips Manufacturing Company (National Gypsum Company) I-studs, or the Dietrich Industries C-T studs and U- or J-tracks. The galvanized C-T or I-studs are available in widths of 2 1/2 inches, 4 inches and 6 inches (63.5 mm, 102 mm and 152 mm). The studs have a minimum thickness as shown in Table 1, and dimensional details as noted in Figure 1 . Allowable partition heights are

as shown in Table 3 of this report and in evaluation reports ER-3579 and NER-506.

2.2 Material:

2.2.1 Gypsum Wallboard: ProRoc® Type C is a registered trademark for a proprietary gypsum wallboard that complies with ASTM C 36 for Type X gypsum wallboard. ProRoc® Type X gypsum wallboard complies with ASTM C 36. The 1-inch (25.4 mm) ProRoc® Shaftliner complies with physical property requirements in ASTM C 442.

2.2.2 Steel: The steel studs are fabricated from galvanized steel complying with the requirements for ASTM A 653 SS Grade 33, having a minimum yield strength of 33,000 psi (228 MPa). The minimum design bare-steel thicknesses for the individual stud types are noted in Table 1. Studs being manufactured from steel having minimum design steel thicknesses of 0.0183 inch and 0.0325 inch (0.465 mm and 0.826 mm) have a G40 and G60 galvanized coating, respectively.

2.3 Two-hour-rated Partition—Finished One Side:

The construction consists of steel studs and tracks faced on one side with 1-inch-thick (25.4 mm) ProRoc® Shaftliner and on the opposite side with two layers of either 1/2-inch-thick (12.7 mm) ProRoc® Type C or 5/8-inch-thick (15.9 mm) ProRoc® Type X gypsum wallboard. The J-track is installed along the ceiling line and vertically to abutting partitions with fasteners spaced a maximum of 24 inches (610 mm) on center. The U-track or J-track is installed along the floor line. Steel studs are installed at 24 inches (610 mm) on center. The 1-inch-thick (25.4 mm) ProRoc® Shaftliner panels are erected vertically, with peripheral shaftliner edges secured to the U- and J-tracks using 1 5/8-inch-long (41 mm), minimum No. 6, Type S screws, spaced 24 inches (610 mm) on center. The other edge and the edges of adjacent Shaftliner panels are secured between the stud flanges with no screw attachments required. On the opposite side, two layers of 1/2-inch-thick (12.7 mm) ProRoc® Type C, or two layers of 5/8-inch-thick (15.9 mm) ProRoc® Type X gypsum wallboard panels, are secured over the studs with the base layer placed horizontally, perpendicular to framing, and fastened to the studs and tracks using 1-inch-long (25.4 mm), No. 6, Type S buglehead screws at 24 inches (610 mm) on center. The face layer is placed vertically, parallel to framing, over the base layer and fastened using 1 5/8-inch-long (41 mm), No. 6, Type S screws spaced 12 inches (305 mm) on center. Base layer joints must be staggered with respect to joints in the face layer. The exposed wallboard joints and screws are sealed using a joint-tape system. The assembly is illustrated in Figure 2.

ICC-ES legacy reports are not to be construed as representing aesthetics or any other attributes not specifically addressed, nor are they to be construed as an endorsement of the subject of the report or a recommendation for its use. There is no warranty by ICC Evaluation Service, Inc., express or implied, as to any finding or other matter in this report, or as to any product covered by the report.



2.4 Two-hour-rated Partition—Finished Both Sides:

Construction details involving the C-T or I-studs and tracks and 1-inch (25.4 mm) shaftliner are identical to those for the system described in Section 2.3, except that a single layer of 1/2-inch (12.7 mm) ProRoc® Type C or 5/8-inch (15.9 mm) ProRoc® Type X gypsum wallboard is installed horizontally, perpendicular to framing, over the shaftliner and installed vertically, parallel to the framing on the open studs using 1-inch (25.4 mm), No. 6, Type S screws 12 inches (305 mm) on center. Joints are staggered or offset between succeeding gypsum board layers. All face layer joints are taped. See Figure 3.

2.5 One-hour-rated Partition—Finished One Side:

Construction details are identical to those for the finished one-side system described in Section 2.3, except that a single layer of 5/8-inch-thick (15.9 mm) ProRoc® Type X gypsum wallboard is applied horizontally, perpendicular to framing, to the open-stud-face side using 1-inch-long (25.4 mm), No. 6, Type S screws spaced 12 inches (305 mm) on center in the field and 8 inches (203 mm) on center along the perimeter. Exposed joints and screwheads are sealed with a joint-tape system. See Figure 4.

2.6 Two-hour-rated Partitions with Sound Control:

Construction details are identical to those for the finished one-side system described in Section 2.3, except that a double layer of 1/2-inch-thick (12.7 mm) ProRoc® Type C or a double layer of 5/8-inch-thick (15.9 mm) ProRoc® Type X gypsum wallboard is fastened to 1/2-inch-deep (12.7 mm), minimum No. 25 gage [0.0179 inch (0.45 mm) thick], resilient furring channels installed horizontally at 24 inches (610 mm) on center. The resilient furring channels are fastened to each stud using 3/8-inch-long (9.5 mm), Type S, panhead screws prior to attachment of the two layers of gypsum wallboard. The base layer is attached to the channels using 1-inch-long (25.4 mm), Type S, buglehead drywall screws spaced 24 inches (610 mm) on center along the edges and in the field of the boards, with the first screw 3 inches (76 mm) from the board end. The face layer is attached to the channels using 1 5/8-inch-long (41 mm), No. 6, Type S, buglehead screws spaced 12 inches (305 mm) on center along the edges and in the field of the board, with the first screw 6 inches (152 mm) from the board end.

The cavity must be filled with 1 1/2-inch-thick (38 mm) mineral fiber or fiberglass insulation. When using the I-stud, the insulation must have a minimum 0.75-pcf (12.0 kg/m³) density, and when using the CT stud, a 3-pcf (48.0 kg/m³) density. Top and bottom tracks and both exterior face perimeters must be caulked under the tracks. Partitions constructed in this manner can be recognized as having a minimum STC rating of 50. See Figure 5.

2.7 One-hour- and Two-hour-rated Corridor Ceiling or stair Soffits:

The systems provide fire-resistive protection on corridor ceilings or on the underside of stairs in accordance with Section 1004.3.4 of the UBC. The SCAFCO Corporation I-stud system, as described in Section 2.5 for one-hour construction or Section 2.3 for two-hour construction, is installed in a horizontal orientation as shown in Figure 6 or Figure 2, respectively. The one-hour system described in Section 2.5, using the Phillips Manufacturing Company I-stud, is installed as shown in Figure 6. The I-studs are supported by J-tracks that are attached to existing vertical wall framing members using mechanical fasteners spaced a maximum of 24 inches (610 mm) on center. The fasteners have an assigned design load of 200 pounds (889.6 N) in either shear or pullout. The I-studs are attached, at each end, to the J-track using two 1/2-inch (12.7 mm), No. 6, Type S-12 panhead

screws. Allowable horizontal spans using the SCAFCO Corporation I-stud are as noted in Table 2. Horizontal spans using the Phillips Manufacturing Company I-stud are as noted in evaluation report ER-3579.

2.8 Two-hour-rated Horizontal Membrane and Duct Protection:

The J-track and SCAFCO Corporation I-studs system as described in Section 2.3 for two-hour construction is installed in a horizontal orientation, using two layers of 1/2-inch (12.7 mm) ProRoc® Type C gypsum wallboard, with the first layer installed at right angles to the I-studs and the second layer installed parallel to the I-studs. In addition, a single layer of 1/2-inch (12.7 mm) ProRoc® Type C gypsum wallboard is progressively installed horizontally, perpendicular to framing over the 1-inch (25.4 mm) ProRoc® Shaftliner panels as the shaftliner panels are installed using 1-inch-long (25.4 mm), No. 6, Type S buglehead screws at 24 inches (610 mm) on center as shown in Figure 7. The second layer of 1/2-inch (12.7 mm) gypsum wallboard is attached either by using 1/2-inch (12.7 mm) beads of joint compound, at 12 inches (305 mm) on center, or by using 1 1/2-inch (38 mm), No. 6 Type S screws, at 12 inches (305 mm) on center. The allowable horizontal spans are as noted in Table 2.

2.9 Identification:

The 1-inch-thick (25.4 mm) ProRoc® Shaftliner is identified as "ProRoc® Shaftliner" on an Underwriters Laboratories Inc. label that appears on the back of each piece. The 5/8-inch-thick (15.9 mm) ProRoc® Type X and 1/2-inch-thick (12.7 mm) ProRoc® Type C gypsum wallboards are each identified by an Underwriters Laboratories Inc. label that appears on the back of each piece and on the bundling tape. Each stud member is identified by the manufacturer's name (SCAFCO Corporation, Phillips Manufacturing Company, or Dietrich Industries Inc.), the steel thickness, the yield strength and the evaluation report number (ICBO ES ER-4924, NER-506 or ICBO ES ER-3579 as applicable).

3.0 EVIDENCE SUBMITTED

Reports of tests in accordance with the ICBO ES Acceptance Criteria for Determining Limiting Heights of Composite Walls Constructed of Gypsum Board and Steel Studs (AC86), dated July 1995; reports of fire endurance tests in accordance with UBC Standard 7-1; sound transmission tests in accordance with ASTM E 90 and E 413; and installation drawings and brochures.

4.0 FINDINGS

That the CertainTeed Gypsum, Inc. ProRoc® Gypsum Shaftwall Systems described in this report are acceptable partitions under the 1997 Uniform Building Code™ for one- and two-hour fire-resistive construction, subject to the following conditions:

- 4.1 The materials and methods of installation comply with this report and the manufacturer's instructions.
- 4.2 The maximum unsupported partition heights are as set forth in either Table 3 of this report or evaluation report ER-3579 or NER-506, as applicable.
- 4.3 The maximum horizontal spans for the systems described in Section 2.7 or 2.8, using the SCAFCO Corporation I-studs, are as set forth in Table 2.
- 4.4 The minimum steel thicknesses for the C-T and I-studs are as indicated in Table 1.
- 4.5 All cut openings and horizontal joints in the shaftliner used with the finished one-side systems must be encased within the metal framing system.

As an alternative, minimum 6-inch-wide (152.4 mm) strips of 1/2-inch-thick (12.7 mm) ProRoc® Type C gypsum wallboard, attached using two 1 1/2-inch-long (38 mm) Type G screws on each side of the joint, may be used.

4.6 Studs are manufactured at one of the following facilities: 6200 East Main Avenue, Spokane, Washington; 504 Walnut Street, Niles, Ohio; or 1435 West 165th Street, Hammond, Indiana.

This report is subject to re-examination in one year.

TABLE 1—STUD TYPE AND STEEL THICKNESS^{1,3}

STUD DEPTH (inches)	MINIMUM BARE STEEL THICKNESS ²		
	Phillips Manufacturing I-Stud	SCAFCO I-Stud (inch)	Dietrich C-T Stud (inch)
2 1/2	0.020 inch (25 gage)	0.0183	0.0219
	0.0329 inch (20 gage)	0.0325	0.0304
	NA	NA	0.0361
4	0.020 inch (25 gage)	0.0183	0.0219
	0.0329 inch (20 gage)	0.0325	0.0333
	0.040 inch (19 gage)	NA	0.038
6	0.020 inch (25 gage)	0.0183	0.0219
	0.0329 inch (20 gage)	0.0325	0.0333
	0.040 inch (19 gage)	NA	0.038

For SI: 1 inch = 25.4 mm, 1psi = 6.89 kPa.

¹Steel with a minimum yield strength of 33,000 psi.

²Minimum design bare (uncoated) steel thickness.

³NA = not applicable.

TABLE 2—MAXIMUM HORIZONTAL SPANS USING SCAFCO I-STUD^{1,8}

I-STUD SIZE (inches)	STUD THICKNESS (nominal gage/inch)	CORRIDOR CEILING AND STAIR SOFFIT ²		HORIZONTAL MEMBRANE AND DUCT PROTECTION ^{3,4}
		One-Hour-Fire-Resistance Rated ⁵	Two-Hour-Fire-Resistance Rated ⁶	Two-Hour-Fire-Resistance Rated ⁷
2 1/2	25/0.0183	7"-10"	8'-8"	7'-6"
2 1/2	20/0.0325	9'-1"	10'-6"	10'-0"
4	25/0.0183	NA	10'-9"	10'-2"
4	20/0.0325	NA	13'-2"	11'-6"
6	20/0.0325	NA	16'-10"	14'- 8"

For SI: 1 inch = 25.4 mm, 1psi = 6.89 kPa, 1 psf = 47.9 Pa.

¹Systems are designed to support their own dead weight only, and should not be used where there is access to an attic or loft space above, or anywhere else where there is any probability of storage above.

²Load of 10 psf and deflection limitation of L/360.

³Load of 15 psf and deflection limitation of L/360.

⁴Ducts are permitted to be designed as a separate system and are not part of a floor/ceiling or roof/ceiling assembly.

⁵See Figure 4. Minimum 5/8-inch-thick ProRoc® Type X gypsum panel.

⁶See Figure 2. Minimum 1/2-inch-thick ProRoc® Type C gypsum panel.

⁷See Figure 7.

⁸NA = not applicable.

TABLE 3—ALLOWABLE WALL HEIGHTS FOR THE I-STUD (TWO-HOUR-FIRE-RESISTANCE RATED WALL)^{1,2,3,4}

STUD DEPTH (inches)	FIRE- RESISTANCE RATING	STEEL THICKNESS (inch)	DEFLECTION	DESIGN LOAD (psf)			
				5	7.5	10	15
2½	1-hour	0.0183/ 25 gage	L/120	13'-10"	9'-1"	7'-10"	6'-4"
			L/240	11'-2"	9'-1"	7'-10"	6'-4"
			L/360	10'-0"	8'-9"	7'-10"	6'-4"
2½	1-hour	0.0325/ 20 gage	L/120	16'-5"	14'-4"	11'-3"	9'-2"
			L/240	13'-1"	11'-4"	10'-4"	9'-1"
			L/360	11'-4"	10'-0"	9'-1"	7'-11"
2½	2-hour	0.0183/ 25 gage	L/120	14'-4"	11'-8"	10'-2"	8'-7"
			L/240	12'-5"	10'-10"	9'-10"	8'-7"
			L/360	10'-10"	9'-6"	8'-8"	7'-6"
4	2-hour	0.0183/ 25 gage	L/120	17'-4"	14'-5"	12'-3"	10'-0"
			L/240	16'-9"	14'-5"	10'-9"	8'-10"
			L/360	14'-8"	12'-6"	10'-9"	8'-10"
2½	2-hour	0.0325/ 20 gage	L/120	20'-9"	16'-11"	14'-8"	11'-11"
			L/240	16'-5"	14'-4"	13'-0"	11'-4"
			L/360	14'-4"	12'-3"	10'-6"	10'-0"
4	2-hour	0.0325/ 20 gage	L/120	22'-8"	18'-6"	16'-0"	13'-1"
			L/240	19'-0"	16'-8"	15'-1"	13'-1"
			L/360	16'-7"	14'-6"	13'-2"	11'-6"
6	2-hour	0.0325/ 20 gage	L/120	25'-10"	21'-1"	18'-3"	14'-11"
			L/240	24'-3"	21'-1"	18'-3"	14'-11"
			L/360	21'-2"	18'-6"	16'-10"	14'-8"

For SI: 1 inch = 25.4 mm, 1foot = 305 mm, 1 psf = 47.9 Pa.

¹Allowable heights are based on transverse load tests complying with AC86, dated July 1995, with studs spaced a maximum of 24 inches on center.

²Limiting height is based on the lesser height of deflection or strength.

³ Limiting height with deflection greater than 14 feet are based on strength results of 14-foot assemblies.

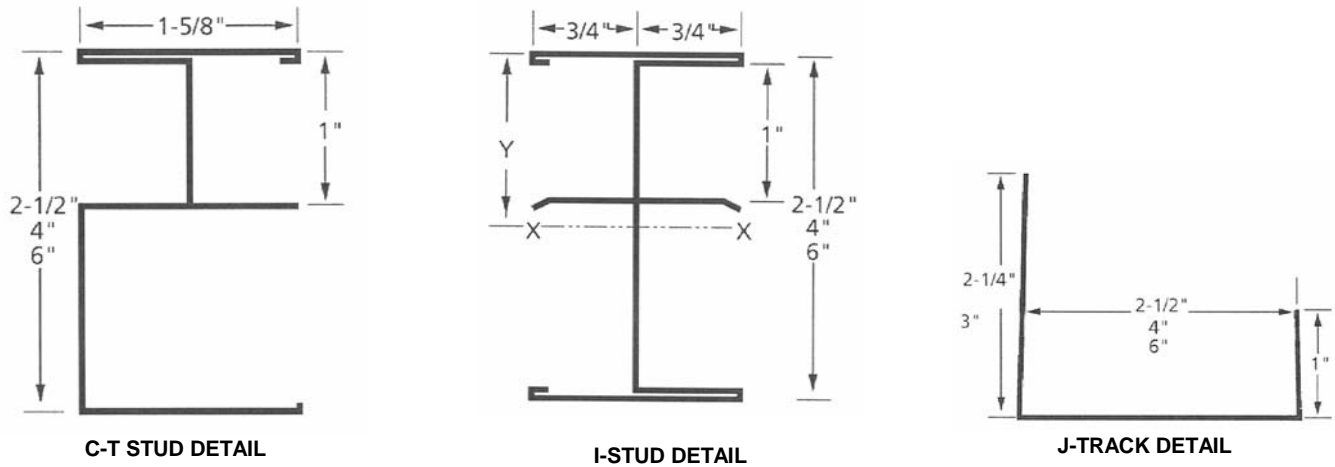
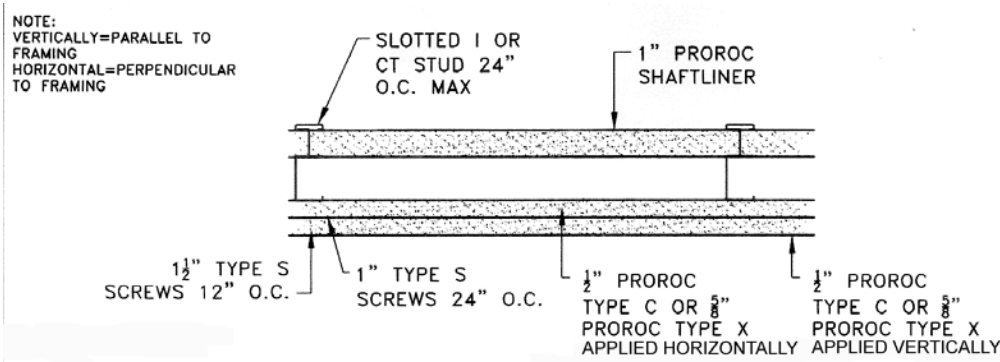
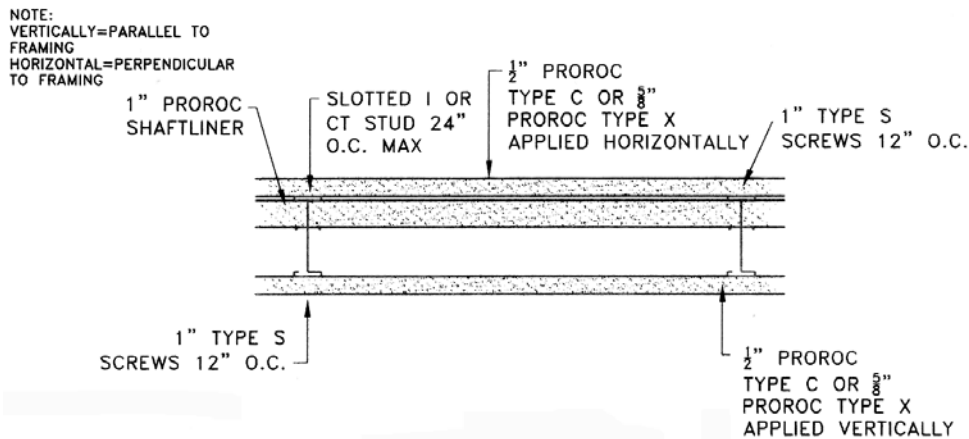

FIGURE 1—DIMENSIONAL DETAILS



For SI: 1 inch = 25.4 mm.

FIGURE 2—2-HOUR RATED PARTITION FINISHED ONE SIDE



For SI: 1 inch = 25.4 mm.

FIGURE 3—2-HOUR RATED PARTITION FINISHED BOTH SIDES

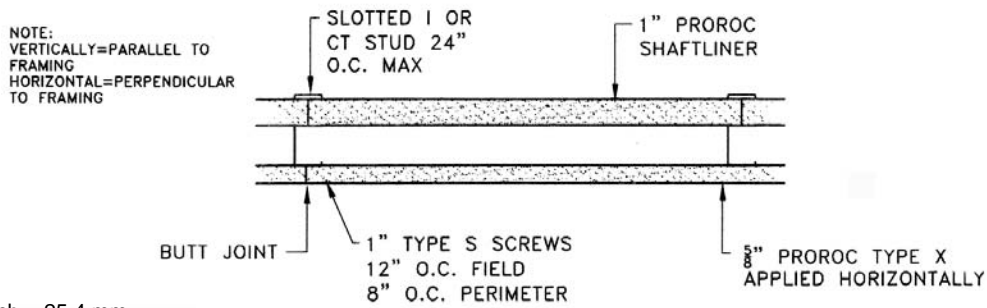

For SI: 1 inch = 25.4 mm.

FIGURE 4—1-HOUR RATED PARTITION FINISHED ONE SIDE

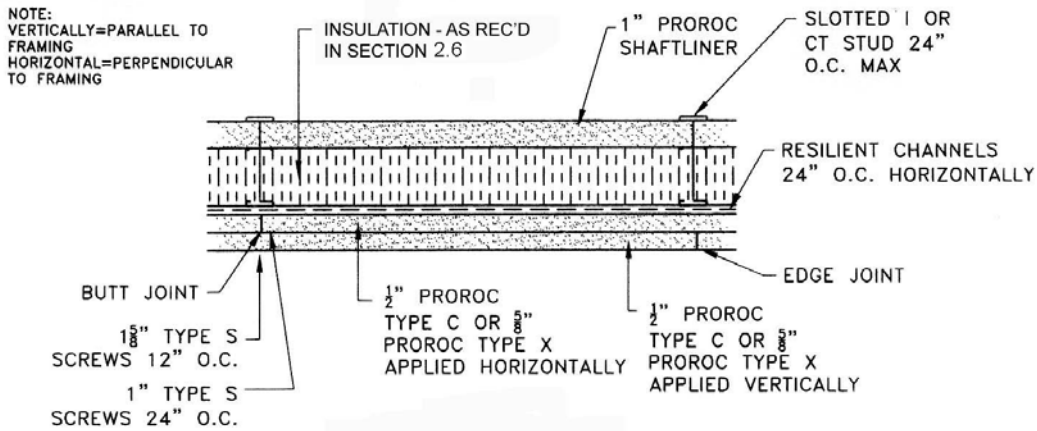

For SI: 1 inch = 25.4 mm

FIGURE 5—2-HOUR RATED PARTITION WITH SOUND CONTROL

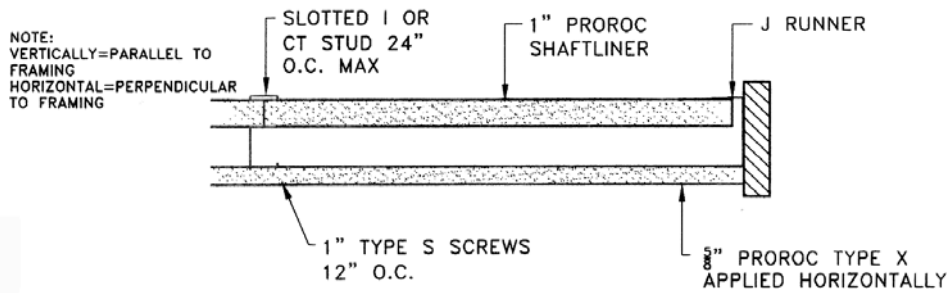

For SI: 1 inch = 25.4 mm

FIGURE 6—2-HOUR RATED HORIZONTAL CEILING

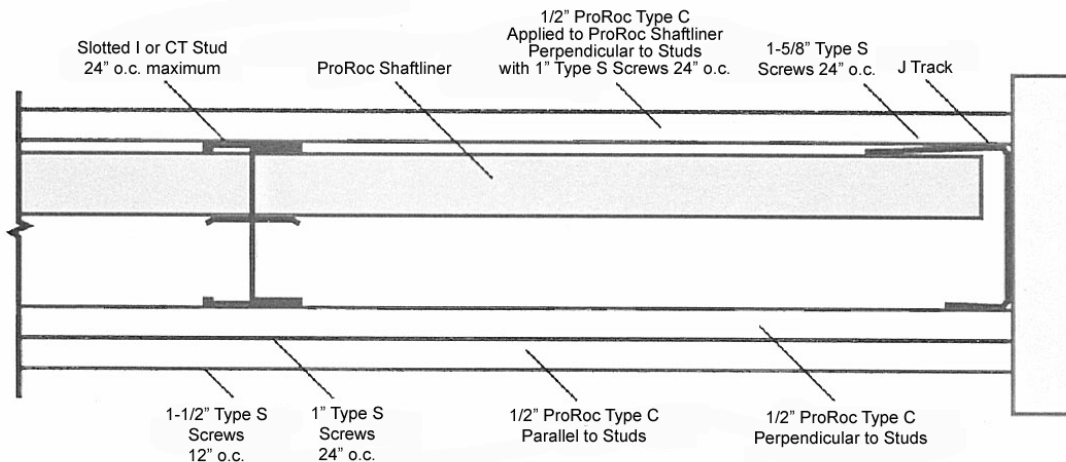

For SI: 1 inch = 25.4 mm

FIGURE 7—2-HOUR RATED HORIZONTAL MEMBRANE AND DUCT PROTECTION